

Name _____

Polygons

COMMON CORE STANDARD CC.5.G.3

Classify two-dimensional figures into categories based on their properties.

Name each polygon. Then tell whether it is a *regular polygon* or *not a regular polygon*.

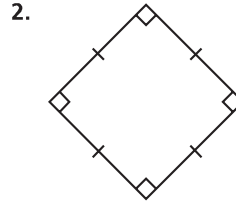
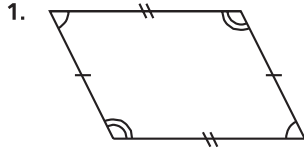

4 sides, 4 vertices, 4 angles means it is a **quadrilateral**. The sides are not all congruent, so it is **not regular**.

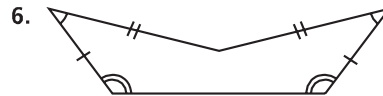
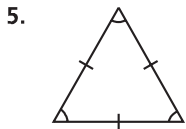
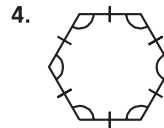
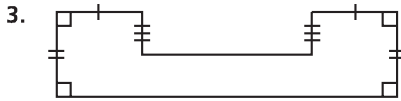

Problem Solving **REAL WORLD**

7. Sketch nine points. Then, connect the points to form a closed plane figure. What kind of polygon did you draw?

8. Sketch seven points. Then, connect the points to form a closed plane figure. What kind of polygon did you draw?

Lesson Check (CC.5.G.3)

1. Which of the following is a regular pentagon?

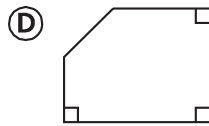
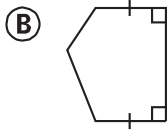
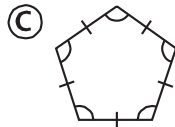
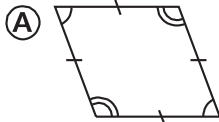

2. Which of the following is NOT a regular polygon?

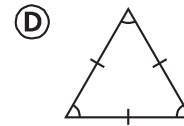
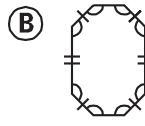
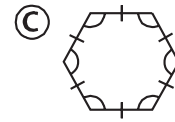
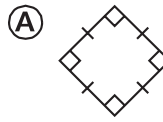

Spiral Review (CC.5.OA.2, CC.5.NBT.7, CC.5.MD.1)

3. Ann needs 42 feet of fabric to make a small quilt. How many yards of fabric should she buy? (Lesson 10.1)

- (A) 13 yards
- (B) 14 yards
- (C) 21 yards
- (D) 126 yards

4. Todd begins piano practice at 4:15 P.M. and ends at 5:50 P.M. How long does he practice? (Lesson 10.7)

- (A) 25 minutes
- (B) 35 minutes
- (C) 1 hour 25 minutes
- (D) 1 hour 35 minutes

5. Jenna is organizing her barrettes into 6 boxes. She puts the same number of barrettes in each box. If Jenna has 30 barrettes, which expression can you use to find the number of barrettes in each box? (Lesson 1.10)

- (A) 6×30
- (B) $30 + 6$
- (C) $30 - 6$
- (D) $30 \div 6$

6. Melody had \$45. She spent \$32.75 on a blouse. Then her mother gave her \$15.50. How much money does Melody have now? (Lesson 3.11)

- (A) \$12.25
- (B) \$27.75
- (C) \$48.25
- (D) \$60.50

Name _____

Triangles

COMMON CORE STANDARDS CC.5.G.3, CC.5.G.4

Classify two-dimensional figures into categories based on their properties.

Classify each triangle. Write *isosceles*, *scalene*, or *equilateral*. Then write *acute*, *obtuse*, or *right*.

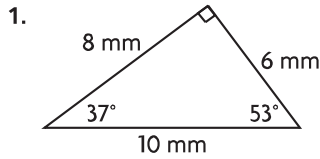

None of the side measures are equal. So, it is **scalene**. There is a right angle, so it is a **right** triangle.

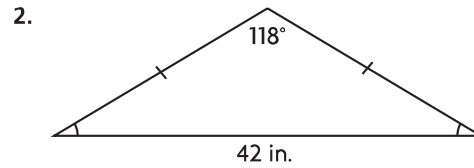

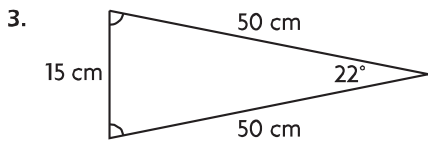

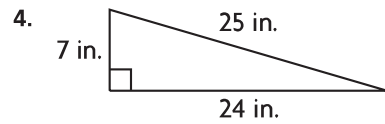

A triangle has sides with the lengths and angle measures given. Classify each triangle. Write *scalene*, *isosceles*, or *equilateral*. Then write *acute*, *obtuse*, or *right*.

5. sides: 44 mm, 28 mm, 24 mm
angles: 110°, 40°, 30°

6. sides: 23 mm, 20 mm, 13 mm
angles: 62°, 72°, 46°

Problem Solving **REAL WORLD**

7. Mary says the pen for her horse is an acute right triangle. Is this possible? **Explain.**

8. Karen says every equilateral triangle is acute. Is this true? **Explain.**

Lesson Check (CC.5.G.3, CC.5.G.4)

1. Which of the following triangles is impossible to draw?
- (A) right obtuse triangle
 - (B) right scalene triangle
 - (C) acute isosceles triangle
 - (D) obtuse scalene triangle

2. What is the classification of the following triangle?

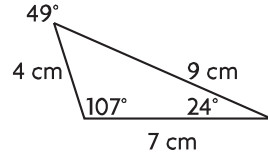

- (A) scalene
- (B) right
- (C) isosceles
- (D) acute

Spiral Review (CC.5.MD.1, CC.5.G.3)

3. How many tons are equal to 40,000 pounds? (Lesson 10.3)
- (A) 2 tons
 - (B) 4 tons
 - (C) 20 tons
 - (D) 40 tons

4. Which measurement is greatest? (Lesson 10.5)
- (A) 6 kilometers
 - (B) 60 meters
 - (C) 600 centimeters
 - (D) 6,000 millimeters

5. Which polygon is shown? (Lesson 11.1)
- (A) quadrilateral
 - (B) pentagon
 - (C) hexagon
 - (D) octagon

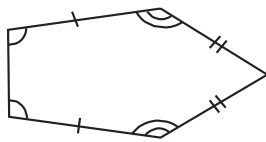

6. Which of the following is a regular polygon? (Lesson 11.1)

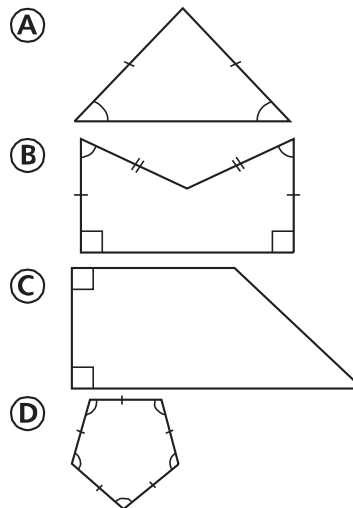

Name _____

Quadrilaterals

COMMON CORE STANDARD CC.5.G.4

Classify two-dimensional figures into categories based on their properties.

Classify the quadrilateral in as many ways as possible.

Write *quadrilateral*, *parallelogram*, *rectangle*, *rhombus*, *square*, or *trapezoid*.

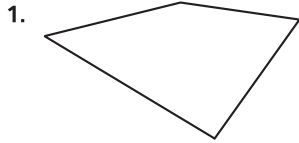

It has 4 sides, so it is a quadrilateral.
None of the sides are parallel, so there is
no other classification.

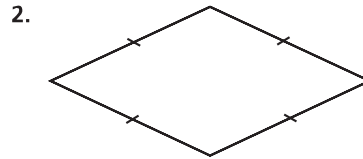

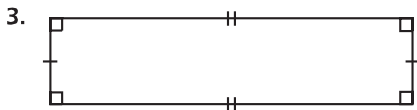

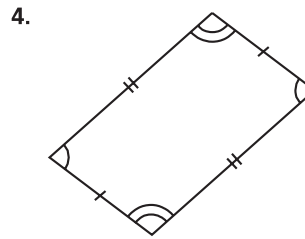

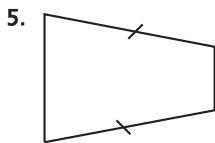



Problem Solving



7. Kevin claims he can draw a trapezoid with three right angles. Is this possible? **Explain.**

8. "If a figure is a square, then it is a regular quadrilateral." Is this true or false? **Explain.**

Lesson Check (CC.5.G.4)

1. A certain parallelogram has two pairs of parallel sides. Based on this, which of the following classifications is NOT correct?
 - (A) quadrilateral
 - (B) rectangle
 - (C) square
 - (D) trapezoid
2. Which of the following is NOT always true about a rhombus?
 - (A) All sides are congruent.
 - (B) All angles are congruent.
 - (C) It has two pairs of parallel sides.
 - (D) It has two pairs of congruent angles.

Spiral Review (CC.5.NF.3, CC.5.MD.1, CC.5.G.3, CC.5.G.4)

3. How many kilograms are equal to 5,000 grams? (Lesson 10.5)
 - (A) 500 kilograms
 - (B) 50 kilograms
 - (C) 5 kilograms
 - (D) 0.5 kilogram
4. The sides of a triangle measure 6 inches, 8 inches, and 10 inches. The triangle has one 90° angle. What type of triangle is it? (Lesson 11.2)
 - (A) scalene right
 - (B) isosceles right
 - (C) equilateral right
 - (D) scalene acute
5. A warehouse has 355 books to ship. Each shipping carton holds 14 books. How many cartons does the warehouse need to ship all of the books? (Lesson 2.7)
 - (A) 5
 - (B) 25
 - (C) 26
 - (D) 30
6. Which of the following statements is NOT true? (Lesson 11.1)
 - (A) A polygon has the same number of angles as it has sides.
 - (B) In a regular polygon, all sides are congruent, and all angles are congruent.
 - (C) Some triangles are regular.
 - (D) All heptagons have 6 vertices.

Name _____

Problem Solving • Properties of Two-Dimensional Figures

COMMON CORE STANDARD CC.5.G.3

Classify two-dimensional figures into categories based on their properties.

Solve each problem.

1. Marcel thinks that quadrilateral $ABCD$ at the right has two pairs of congruent sides, but he does not have a ruler to measure the sides. How can he show that the quadrilateral has two pairs of congruent sides?

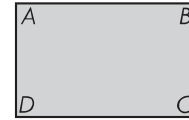

He can fold the quadrilateral in half both ways. If both sets of sides match, then they are congruent.

2. If what Marcel thinks about his quadrilateral is true, what type of quadrilateral does he have? _____

3. Richelle drew hexagon $KLMNOP$ at the right. She thinks the hexagon has six congruent angles. How can she show that the angles are congruent without using a protractor to measure them?

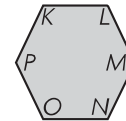

4. Jerome drew a triangle with vertices S , T , and U . He thinks $\angle TSU$ and $\angle TUS$ are congruent. How can Jerome show that the angles are congruent without measuring the angles?

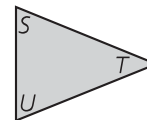

5. If Jerome is correct, what type of triangle did he draw?

Lesson Check (CC.5.G.3)

1. Peter knows that pentagon $DEFGH$ has 5 congruent sides. How can he determine if the pentagon has 5 congruent angles without measuring?

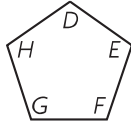

- (A) He can trace and fold the figure to check if the angles match up.
- (B) All pentagons have congruent angles.
- (C) If a polygon has an odd number of angles, the angles cannot be congruent.
- (D) He can use an index card to check that at least one angle is right.

2. Tina knows that quadrilateral $WXYZ$ has 2 pairs of congruent angles. She thinks that all 4 sides look congruent but she does not have a ruler. How can Tina determine whether she is correct?

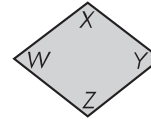

- (A) She can fold the figure to check that WX and YZ match up.
- (B) She can fold the figure to check that XY and WZ match up.
- (C) She can fold the figure along both diagonals, XZ and WY , to check if the sides match.
- (D) The sides cannot all be congruent if the angles are not all congruent.

Spiral Review (CC.5.MD.1, CC.5.G.3, CC.5.G.4)

3. How many ounces are in 50 pounds?

(Lesson 10.3)

- (A) 800 ounces
- (B) 500 ounces
- (C) 400 ounces
- (D) 200 ounces

4. How many minutes are there in 40 hours?

(Lesson 10.7)

- (A) 4,000 minutes
- (B) 2,400 minutes
- (C) 960 minutes
- (D) 240 minutes

5. Which of the following angle measures could NOT represent an angle measure of an acute triangle? (Lesson 11.2)

- (A) 33°
- (B) 78°
- (C) 81°
- (D) 92°

6. Which of the following angle measures represents the measure of each of the four angles of a square? (Lesson 11.3)

- (A) 45°
- (B) 60°
- (C) 90°
- (D) 100°

Name _____

Three-Dimensional Figures

COMMON CORE STANDARD CC.5.MD.3

Geometric measurements: understand concepts of volume and relate volume to multiplication and to addition.

Classify the solid figure. Write *prism*, *pyramid*, *cone*, *cylinder*, or *sphere*.

1.

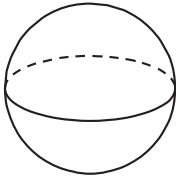

There are no bases. There is 1 curved surface. It is a

sphere

2.

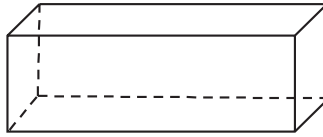

3.

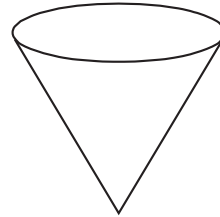

Name the solid figure.

4.

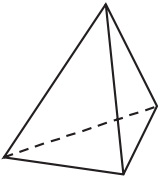

5.

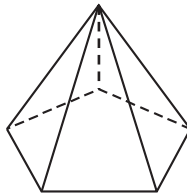

6.



7.

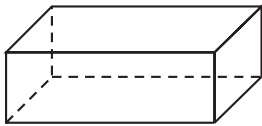

8.

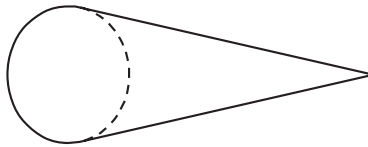

9.

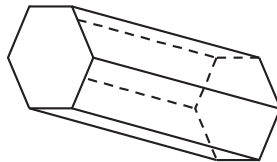

Problem Solving **REAL WORLD**

10. Darrien is making a solid figure out of folded paper. His solid figure has six congruent faces that are all squares. What solid figure did Darrien make?

11. Nanako said she drew a square pyramid and that all of the faces are triangles. Is this possible? **Explain.**

Lesson Check (CC.5.MD.3)

- Luke made a model of a solid figure with 1 circular base and 1 curved surface. What solid figure did he make?
 - cone
 - cylinder
 - sphere
 - triangular pyramid
- Which of the following does NOT have any rectangular faces?
 - pentagonal prism
 - hexagonal pyramid
 - rectangular prism
 - square pyramid

Spiral Review (CC.5.NF.1, CC.5.MD.1, CC.5.G.3, CC.5.G.4)

- Without measuring, how can you determine whether two sides of a polygon are congruent? (Lesson 11.4)
 - If the two sides look congruent, you can assume they are congruent.
 - Cut out the polygon and fold the two sides onto each other. If the sides match up, you can assume they are congruent.
 - Cut out the polygon and fold two of the angles onto each other. If the angles match up, you can assume the sides are also congruent.
 - It is not possible to determine whether two sides of a polygon are congruent without measuring.
- Latasha made 128 ounces of punch. How many cups of punch did Latasha make? (Lesson 10.2)
 - 4 cups
 - 8 cups
 - 16 cups
 - 32 cups
- James has $4\frac{3}{4}$ feet of rope. He plans to cut off $1\frac{1}{2}$ feet from the rope. How much rope will be left? (Lesson 6.6)
 - $\frac{1}{4}$ foot
 - 3 feet
 - $3\frac{1}{4}$ feet
 - $6\frac{1}{2}$ feet
- Which of the following statements is NOT true? (Lesson 11.3)
 - Some quadrilaterals are squares.
 - All rhombuses are quadrilaterals.
 - All squares are rectangles.
 - Some trapezoids are parallelograms.

Name _____

Unit Cubes and Solid Figures

COMMON CORE STANDARD CC.5.MD.3a

Geometric measurement: understand concepts of volume and relate volume to multiplication and to addition.

Count the number of cubes used to build each solid figure.

1.

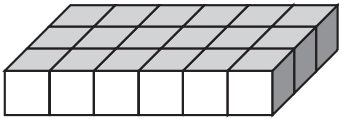

18 unit cubes

2.

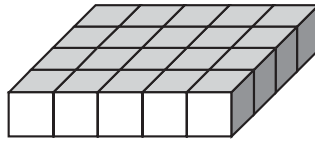

_____ unit cubes

3.

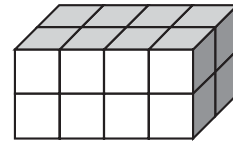

_____ unit cubes

4.

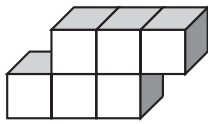

_____ unit cubes

5.

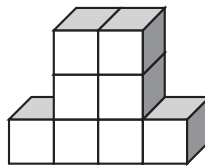

_____ unit cubes

6.

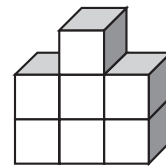

_____ unit cubes

Compare the number of unit cubes in each solid figure. Use $<$, $>$, or $=$.

7.

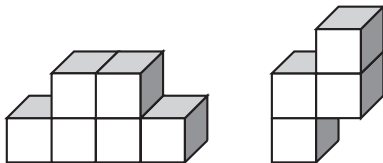

_____ unit cubes ○ _____ unit cubes

8.

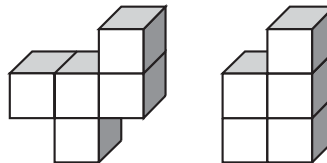

_____ unit cubes ○ _____ unit cubes

Problem Solving **REAL WORLD**

9. A carton can hold 1,000 unit cubes that measure 1 inch by 1 inch by 1 inch. Describe the dimensions of the carton using unit cubes.

10. Peter uses unit cubes to build a figure in the shape of the letter X. What is the fewest unit cubes that Peter can use to build the figure?

Lesson Check (CC.5.MD.3a)

1. Cala stacked some blocks to make the figure below. How many blocks are in Cala's figure?

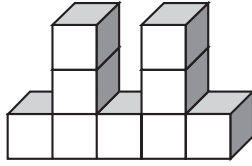

- (A) 7 (C) 9
(B) 8 (D) 10

2. Quentin has 18 unit cubes. How many different rectangular prisms can he build if he uses all of the cubes?

- (A) 4
(B) 6
(C) 8
(D) 18

Spiral Review (CC.5.MD.1, CC.5.MD.3, CC.5.G.4)

3. In what shape are the lateral faces of a pyramid? (Lesson 11.5)

- (A) triangle
(B) square
(C) rectangle
(D) hexagon

4. The Arnold family arrived at the beach at 10:30 A.M. They spent $3\frac{3}{4}$ hours there. What time did they leave the beach? (Lesson 10.7)

- (A) 1:15 P.M.
(B) 2:15 P.M.
(C) 3:15 P.M.
(D) 3:45 P.M.

5. Which of the following is always true about a parallelogram? (Lesson 11.3)

- (A) All sides are congruent.
(B) All angles are congruent.
(C) It has 4 right angles.
(D) Opposite sides are congruent.

6. The tire on Frank's bike moves 75 inches in one rotation. How many rotations will the tire have made after Frank rides 50 feet?

(Lesson 10.4)

- (A) 2
(B) 8
(C) 12
(D) 24

Name _____

Understand Volume

COMMON CORE STANDARDS CC.5.MD.3b, CC.5.MD.4

Geometric measurement: understand concepts of volume and relate volume to multiplication and to addition.

Use the unit given. Find the volume.

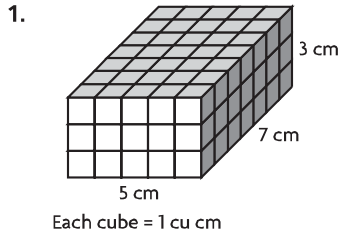

Volume = 105 cu cm

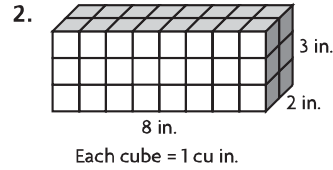

Volume = _____ CU _____

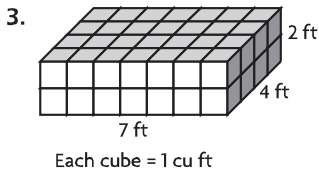

Volume = _____ cu _____

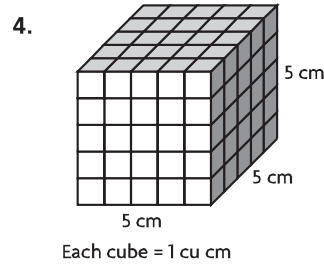

Volume = _____ CU _____

5. Compare the volumes. Write $<$, $>$, or $=$.

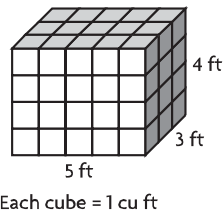

_____ cu ft ○ _____ cu ft

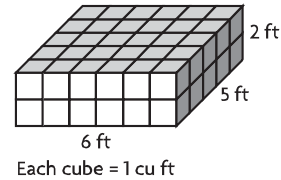

Problem Solving **REAL WORLD**

6. A manufacturer ships its product in boxes with edges of 4 inches. If 12 boxes are put in a carton and completely fill the carton, what is the volume of the carton?

7. Matt and Mindy each built a rectangular prism that has a length of 5 units, a width of 2 units, and a height of 4 units. Matt used cubes that are 1 cm on each side. Mindy used cubes that are 1 in. on each side. What is the volume of each prism?

Lesson Check (CC.5.MD.3b, CC.5.MD.4)

1. Elena packed 48 cubes into this box. Each cube has edges that are 1 centimeter. How many layers of cubes did Elena make?

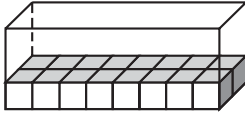

- (A) 2
- (B) 3
- (C) 4
- (D) 8

2. What is the volume of the rectangular prism?

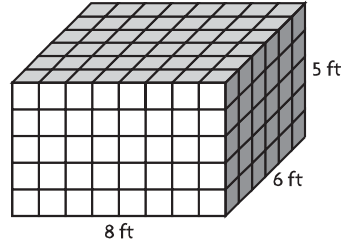

Each cube = 4 cu ft

- (A) 40 cubic inches
- (B) 40 cubic feet
- (C) 240 cubic inches
- (D) 240 cubic feet

Spiral Review (CC.5.MD.1, CC.5.G.1, CC.5.G.3, CC.5.G.4)

3. Juan made a design with polygons. Which polygon in Juan's design is a pentagon?

(Lesson 11.1)

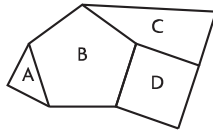

- (A) Figure A
- (B) Figure B
- (C) Figure C
- (D) Figure D

4. Which ordered pair describes the location of point X? (Lesson 9.2)

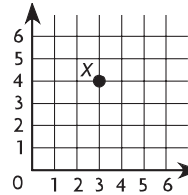

- (A) (3, 4)
- (B) (4, 3)
- (C) (4, 4)
- (D) (3, 3)

5. What is the least number of acute angles that a triangle can have? (Lesson 11.2)

- (A) 0
- (B) 1
- (C) 2
- (D) 3

6. Karen bought 3 pounds of cheese to serve at a picnic. How many ounces of cheese did Karen buy? (Lesson 10.3)

- (A) 24 ounces
- (B) 32 ounces
- (C) 36 ounces
- (D) 48 ounces

Name _____

Estimate Volume

COMMON CORE STANDARD CC.5.MD.4

Geometric measurement: understand concepts of volume and relate volume to multiplication and to addition.

Estimate the volume.

1. Volume of package of paper: 200 cu in.

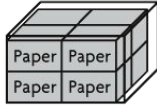

Think: Each package of paper has a volume of 200 cu in. There are 8 packages of paper in the larger box. So, the volume of the large box is about 8 × 200, or 1,600 cubic inches.

Volume of large box: 1,600 cu in.

2. Volume of rice box: 500 cu cm

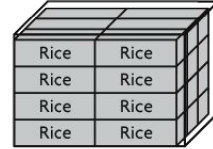

Volume of large box: _____

3. Volume of tea box: 40 cu in.

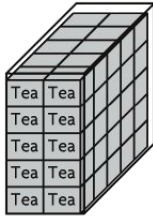

Volume of large box: _____

4. Volume of DVD case: 20 cu in.

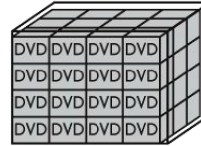

Volume of large box: _____

Problem Solving **REAL WORLD**

5. Theo fills a large box with boxes of staples. The volume of each box of staples is 120 cu cm. Estimate the volume of the large box.

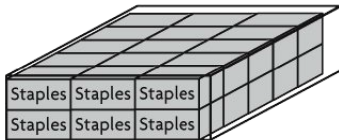

6. Lisa uses pudding boxes to estimate the volume of the box below. The volume of each pudding box is 150 cu in. Estimate the volume of the large box.

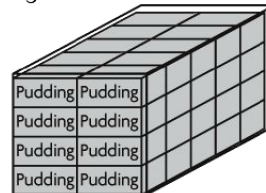

Lesson Check (CC.5.MD.4)

1. Melanie packs boxes of envelopes into a larger box. The volume of each box of envelopes is 1,200 cubic centimeters. Which is the best estimate for the volume of the large box?

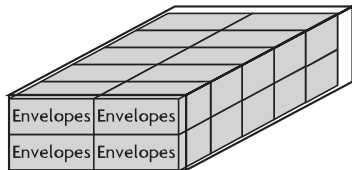

- (A) 2,400 cu cm
- (B) 12,000 cu cm
- (C) 20,000 cu cm
- (D) 24,000 cu cm

2. Calvin packs boxes of greeting cards into a larger box. The volume of each box of greeting cards is 90 cubic inches. Which is the best estimate for the volume of the large box?

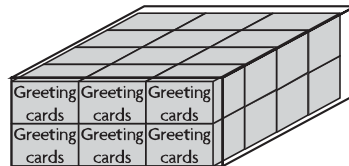

- (A) 216 cu in.
- (B) 240 cu in.
- (C) 2,160 cu in.
- (D) 2,400 cu in.

Spiral Review (CC.5.MD.1, CC.5.MD.3a, CC.5.MD.3b, CC.5.MD.4)

3. Rosa has 16 unit cubes. How many different rectangular prisms can she build with the cubes? (Lesson 11.6)

- (A) 2
- (B) 3
- (C) 4
- (D) 8

4. Each cube represents 1 cubic inch. What is the volume of the prism? (Lesson 11.7)

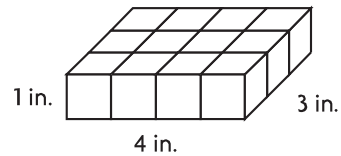

- (A) 1 cu in.
- (B) 4 cu in.
- (C) 8 cu in.
- (D) 12 cu in.

5. A certain aquarium holds 20 gallons of water. How many quarts of water does the aquarium hold? (Lesson 10.2)

- (A) 160 quarts
- (B) 80 quarts
- (C) 10 quarts
- (D) 5 quarts

6. Monique ran in a 5-kilometer race. How many meters did Monique run? (Lesson 10.5)

- (A) 50 meters
- (B) 500 meters
- (C) 5,000 meters
- (D) 50,000 meters

Name _____

Volume of Rectangular Prisms

COMMON CORE STANDARD CC.5.MD.5a

Geometric measurement: understand concepts of volume and relate volume to multiplication and to addition.

Find the volume.

1.

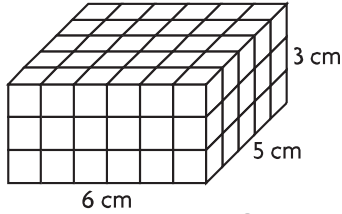

Volume: **90 cm³**

2.

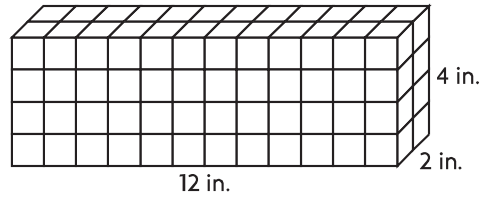

Volume: _____

3.

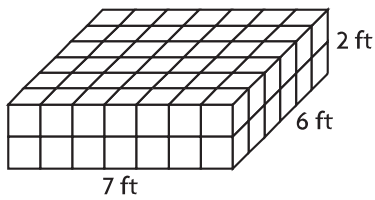

Volume: _____

4.

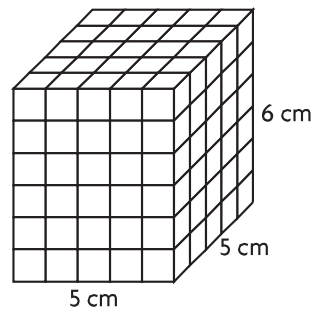

Volume: _____

5.

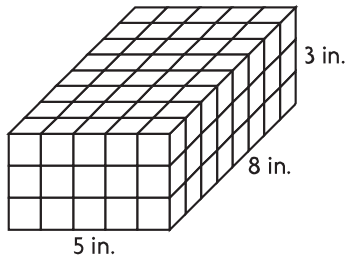

Volume: _____

6.

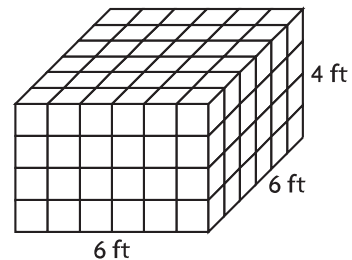

Volume: _____

Problem Solving **REAL WORLD**

7. Aaron keeps his baseball cards in a cardboard box that is 12 inches long, 8 inches wide, and 3 inches high. What is the volume of this box?

8. Amanda's jewelry box is in the shape of a cube that has 6-inch edges. What is the volume of Amanda's jewelry box?

Lesson Check (CC.5.MD.5a)

1. Laini uses 1-inch cubes to build the box shown below. What is the volume of the box?

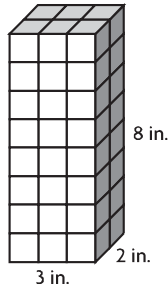

- (A) 13 in.³ (C) 46 in.³
(B) 16 in.³ (D) 48 in.³

2. Mason stacked 1-foot cube-shaped boxes in a warehouse. What is the volume of the stack of boxes?

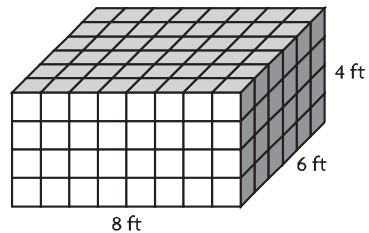

- (A) 19 ft³ (C) 192 ft³
(B) 104 ft³ (D) 208 ft³

Spiral Review (CC.5.MD.1, CC.5.G.3, CC.5.G.4)

3. What type of triangle is shown below? (Lesson 11.2)

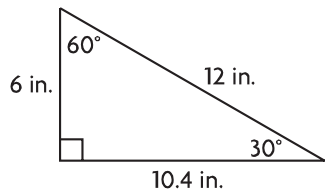

- (A) isosceles right
(B) scalene acute
(C) scalene obtuse
(D) scalene right

5. Suzanne is 64 inches tall. Which of the following is equal to 64 inches? (Lesson 10.1)

- (A) 4 ft (C) 6 ft
(B) 5 ft 4 in. (D) 6 ft 4 in.

4. Which figure is a quadrilateral that has opposite sides that are congruent and parallel? (Lesson 11.4)

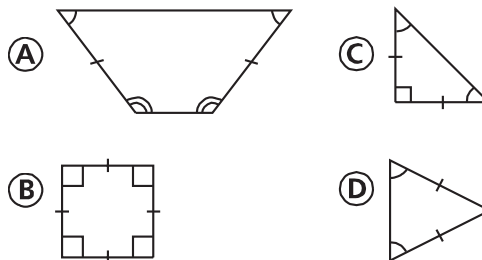

6. Trevor bought 8 gallons of paint to paint his house. He used all but 1 quart. How many quarts of paint did Trevor use? (Lesson 10.4)

- (A) 7 quarts (C) 31 quarts
(B) 15 quarts (D) 47 quarts

Name _____

Apply Volume Formulas

COMMON CORE STANDARDS CC.5.MD.5b

Geometric measurement: understand concepts of volume and relate volume to multiplication and to addition.

Find the volume.

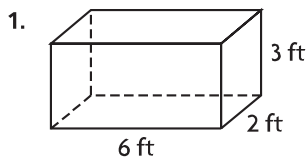

$$V = \underline{l} \times \underline{w} \times \underline{h}$$

$$V = \underline{6} \times \underline{2} \times \underline{3}$$

$$V = \underline{36 \text{ ft}^3}$$

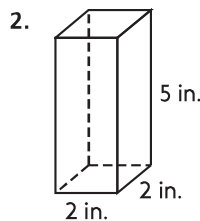

$V = \underline{\hspace{2cm}}$

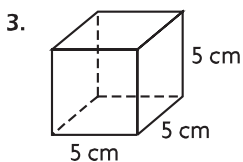

$V = \underline{\hspace{2cm}}$

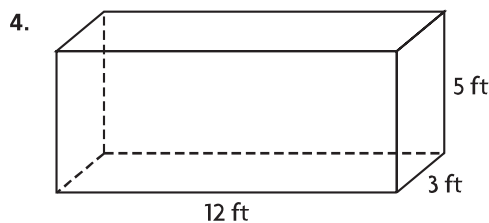

$V = \underline{\hspace{2cm}}$

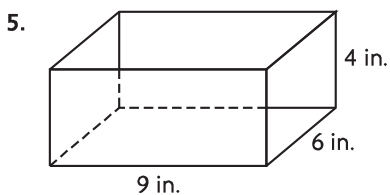

$V = \underline{\hspace{2cm}}$

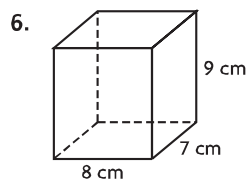

$V = \underline{\hspace{2cm}}$

Problem Solving 

7. A construction company is digging a hole for a swimming pool. The hole will be 12 yards long, 7 yards wide, and 3 yards deep. How many cubic yards of dirt will the company need to remove?

8. Amy rents a storage room that is 15 feet long, 5 feet wide, and 8 feet. What is the volume of the storage room?

Lesson Check (CC.5.MD.5b)

- Sayed is buying a crate for his puppy. The crate is 20 inches long, 13 inches wide, and 16 inches high. What is the volume of the crate?
 - (A) 208 in.³
 - (B) 260 in.³
 - (C) 2,600 in.³
 - (D) 4,160 in.³
- Brittany has a gift box in the shape of a cube. Each side of the box measures 15 centimeters. What is volume of the gift box?
 - (A) 255 cm³
 - (B) 1,350 cm³
 - (C) 3,375 cm³
 - (D) 3,475 cm³

Spiral Review (CC.5.MD.1, CC.MD.2, CC.5.MD.3a, CC.5.MD.4)

- Max packs cereal boxes into a larger box. The volume of each cereal box is 175 cubic inches. Which is the best estimate for the volume of the large box? (Lesson 11.8)
- In health class, students record the weights of the sandwiches they have for lunch. The weights are shown in the line plot below. What is the average weight of one sandwich? (Lesson 9.1)

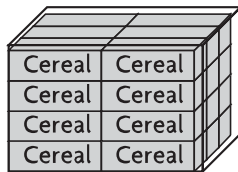

- (A) 210 cu in.
 - (B) 420 cu in.
 - (C) 2,100 cu in.
 - (D) 4,200 cu in.
- Chloe has 20 unit cubes. How many different rectangular prisms can she build with the cubes? (Lesson 11.6)
 - (A) 4
 - (B) 5
 - (C) 10
 - (D) 20
 - Darnell went to the movies with his friends. The movie started at 2:35 P.M. and lasted 1 hour 45 minutes. What time did the movie end? (Lesson 10.7)
 - (A) 3:50 P.M.
 - (B) 4:20 P.M.
 - (C) 4:50 P.M.
 - (D) 5:20 P.M.

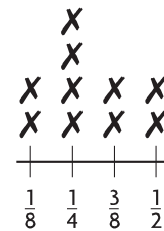

**Weights of Sandwiches
(in pounds)**

Name _____

Problem Solving • Compare Volumes

COMMON CORE STANDARD CC.5.MD.5b

Geometric measurement: understand concepts of volume and relate volume to multiplication and to addition.

Make a table to help you solve each problem.

1. Amita wants to make a mold for a candle. She wants the shape of the candle to be a rectangular prism with a volume of exactly 28 cubic centimeters. She wants the sides to be in whole centimeters. How many different molds can she make?

10 molds

2. Amita decides that she wants the molds to have a square base. How many of the possible molds can she use?

3. Raymond wants to make a box that has a volume of 360 cubic inches. He wants the height to be 10 inches and the other two dimensions to be whole numbers of inches. How many different-sized boxes can he make?

4. Jeff put a small box that is 12 inches long, 8 inches wide, and 4 inches tall inside a box that is 20 inches long, 15 inches wide, and 9 inches high. How much space is left in the larger box?

5. Mrs. Nelson has a rectangular flower box that is 5 feet long and 2 feet tall. She wants the width of the box to be no more than 5 feet. If the width is a whole number, what are the possible volumes for the flower box?

6. Sophina bought 3 yards of trim to put around a rectangular scarf. She wants the width of the scarf to be a whole number that is at least 6 inches and at most 12 inches. If she uses all the trim, what are the possible dimensions of her scarf? Write your answers in inches.

Lesson Check (CC.5.MD.5b)

- Corey bought a container shaped like a rectangular prism to hold his photo collection. If the container has a volume of 480 cubic inches, which of the following could be its dimensions in inches?
 - 3 in. by 8 in. by 10 in.
 - 6 in. by 4 in. by 12 in.
 - 6 in. by 8 in. by 10 in.
 - 8 in. by 4 in. by 8 in.
- Aleka has a box for keepsakes that has a volume of 576 cubic inches. The length of the box is 12 inches and the width is 8 inches. What is the height of the box?
 - 6 inches
 - 20 inches
 - 48 inches
 - 72 inches

Spiral Review (CC.5.MD.1, CC.5.MD.3, CC.5.MD.5a, CC.5.MD.5b)

- A movie is 2 hours and 28 minutes long. It starts at 7:50 P.M. At what time will the movie end? (Lesson 10.7)
 - 9:18 P.M.
 - 9:78 P.M.
 - 10:08 P.M.
 - 10:18 P.M.
- Which of the following does NOT have any rectangular faces? (Lesson 11.5)
 - hexagonal prism
 - pentagonal pyramid
 - rectangular prism
 - square pyramid
- An aquarium is in the shape of a rectangular prism. Its length is 24 inches, its width is 12 inches, and its height is 14 inches. How much water can the aquarium hold? (Lesson 11.10)
 - 168 cubic inches
 - 288 cubic inches
 - 336 cubic inches
 - 4,032 cubic inches
- What is the volume of the rectangular prism shown? (Lesson 11.9)
 - 11 m^3
 - 18 m^3
 - 36 m^3
 - 360 m^3

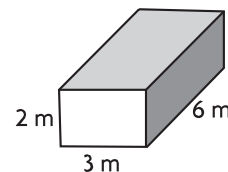

Name _____

Find Volume of Composed Figures

COMMON CORE STANDARD CC.5.MD.5c

Geometric measurement: understand concepts of volume and relate volume to multiplication and to addition.

Find the volume of the composite figure.

1.

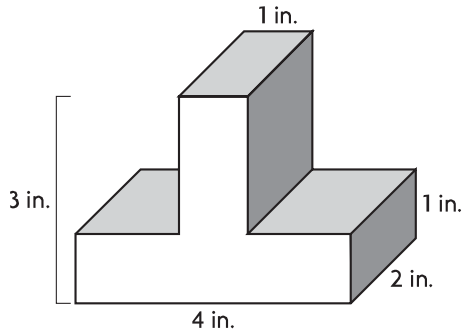

$V =$ _____

2.

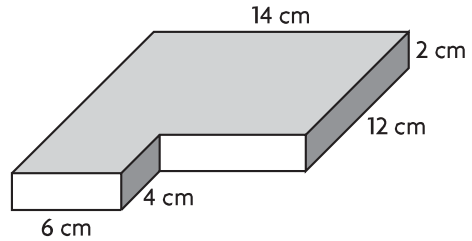

$V =$ _____

3.

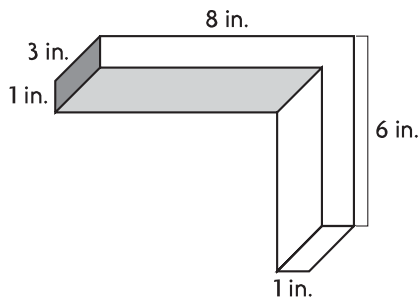

$V =$ _____

4.

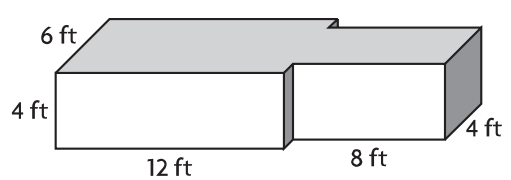

$V =$ _____

Problem Solving **REAL WORLD**

5. As part of her shop class, Jules made the figure below out of pieces of wood. How much space does the figure she made take up?

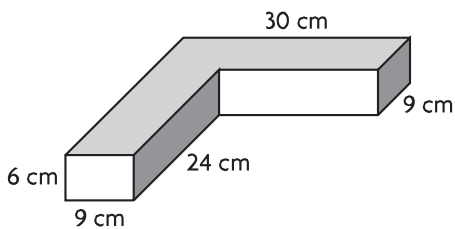

6. What is the volume of the composite figure below?

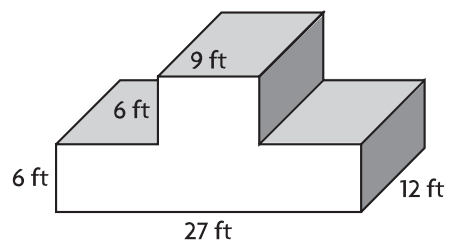

Lesson Check (CC.5.MD.5c)

1. Which expression represents the volume of the composite figure?

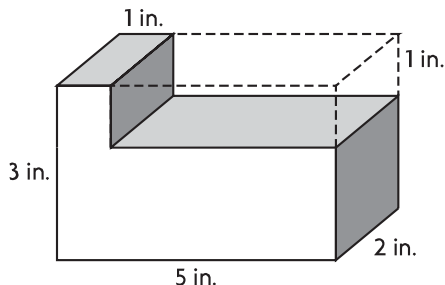

- (A) $(5 \times 2) - (3 \times 1)$
 (B) $5 \times 2 \times 3$
 (C) $(5 \times 2 \times 3) - (4 \times 2 \times 1)$
 (D) $4 \times 2 \times 1$

2. Suppose you take the small prism and stack it on top of the larger prism. What will be the volume of the composite figure?

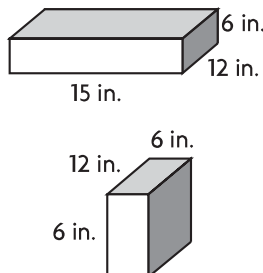

- (A) 432 cubic inches
 (B) 648 cubic inches
 (C) 1,080 cubic inches
 (D) 1,512 cubic inches

Spiral Review (CC.5.NF.6, CC.5.NF.7c, CC.5.MD.5a, CC.5.MD.5b)

3. Jesse wants to build a wooden chest with a volume of 8,100 cubic inches. The length will be 30 inches and the width will be 15 inches. How tall will Jesse's chest be? (Lesson 11.11)

- (A) 18 in.
 (B) 30 in.
 (C) 270 in.
 (D) 540 in.

4. What is the volume of the rectangular prism? (Lesson 11.9)

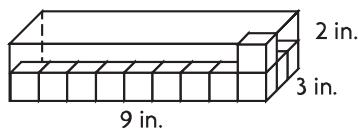

- (A) 14 in.^3
 (B) 27 in.^3
 (C) 45 in.^3
 (D) 54 in.^3

5. Adrian's recipe for cranberry relish calls for $1\frac{3}{4}$ cups of sugar. He wants to use $\frac{1}{2}$ that amount. How much sugar should he use? (Lesson 7.9)

- (A) $1\frac{1}{4}$ cups
 (B) $1\frac{1}{6}$ cups
 (C) $\frac{7}{8}$ cup
 (D) $\frac{1}{2}$ cup

6. Joanna has a board that is 6 feet long. She cuts it into pieces that are each $\frac{1}{4}$ foot long. Which equation represents the number of pieces she cut? (Lesson 8.5)

- (A) $6 \div \frac{1}{4} = n$
 (B) $6 \div 4 = n$
 (C) $\frac{1}{4} \div 6 = n$
 (D) $\frac{1}{4} \div \frac{1}{6} = n$

Name _____

COMMON CORE STANDARDS CC.5.MD.3, CC.5.MD.3a,
CC.5.MD.3b, CC.5.MD.4, CC.5.MD.5a, CC.5.MD.5b,
CC.5.MD.5c, CC.5.G.3, CC.5.G.4

Chapter 11 Extra Practice

Lesson 11.1

Name each polygon. Then tell whether it is a *regular* polygon or *not a regular* polygon.

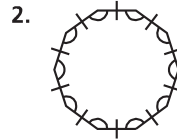
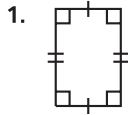

Lesson 11.2

Classify each triangle. Write *isosceles*, *scalene*, or *equilateral*. Then write *acute*, *obtuse*, or *right*.

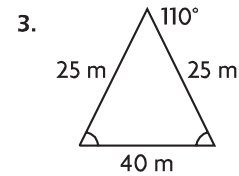
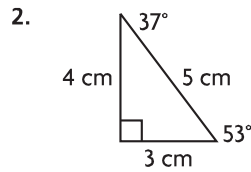
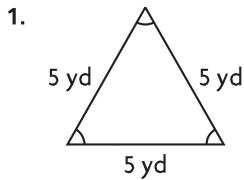

Lesson 11.3

Classify the quadrilateral in as many ways as possible. Write *quadrilateral*, *parallelogram*, *rectangle*, *rhombus*, *square*, or *trapezoid*.

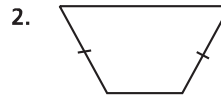
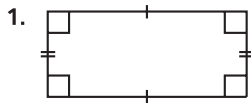

Lesson 11.4

1. Sasha has a triangle with vertices A , B , and C . The triangle has three congruent angles. She wants to show that triangle ABC has three congruent sides, but she does not have a ruler to measure the lengths of the sides. How can she show that the triangle has three congruent sides?

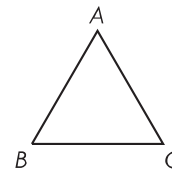

Lesson 11.5

Classify the solid figure. Write *prism*, *pyramid*, *cone*, *cylinder*, or *sphere*.

1.

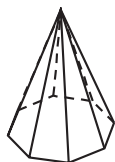

2.

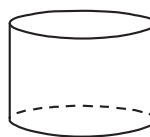

Lessons 11.6 - 11.10

Find the volume.

1.

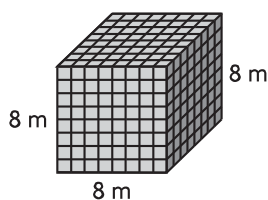

Volume = _____

2.

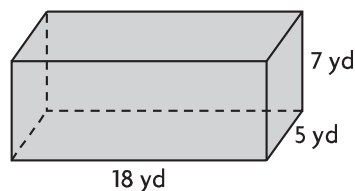

Volume = _____

Lesson 11.11

Solve.

1. One aquarium is 12 inches long, another is 15 inches long, and a third is 18 inches long. They are all 18 inches deep and 12 inches wide. Which aquarium can hold exactly 3,240 cubic inches of water?
